



More information on the website
radwag.com/en/info,w1,GT1

PS 3500.R2.M Precision Balance



PS 3500.R2.M Precision Balance

The drawings, photos and graphics used are for illustrative purposes only.

Functions



Autotest



Dosing



Percent Weighing



Totalizing



Parts counting



Peak hold



Newton unit
measurement



Statistics



Checkweighing



GLP Procedures



Animal weighing



Density determination

Datasheet

	PS 3500.R2.M Precision Balance
Metrological parameters	
Maximum capacity [Max]	3500 g
Minimum load	500 mg
Readability [d]	0,01 g
Verification scale interval [e]	0,1 g
Tare range	-3500 g
Repeatability (Max)	0,008 g
Repeatability (5% Max)	0,005 g
Linearity	±0,02 g
Stabilization time	1,5 s
Adjustment	internal (automatic)
OIML Class	II
Physical parameters	
Leveling system	manual
Display	LCD (backlit)
Protection class	IP 43
Delivery components	Balance, weighing pan, weighing pan shield, power supply
Weighing pan dimensions	195×195 mm
Packaging dimensions	470×380×336 mm
Net weight	4,5 kg
Gross weight	6 kg
Communication interface	
Communication interface	2×RS232 ¹ , USB-A, USB-B, Wi-Fi (option)
Electrical parameters	
Power supply	Adapter: 100 – 240V AC 50/60Hz 0,6A; 12V DC 1,2A Balance: 12 – 15V DC 0,4A max
Environmental conditions	
Operating temperature	+10 ÷ +40 °C

Repeatability is expressed as a standard deviation from 10 weighing cycles. Stabilization time depends on the ambient conditions and the dynamics of weighing pan loading; specified for FAST profile. 1 Barcode scanners, available as weighing instrument accessory, communicate with the instrument via RS232 interface exclusively.

* Wi-Fi® is a registered trademark of Wi-Fi® Alliance.



Accessories

Barcode scanners
Cigarette lighter receptacle power supply cables
USB cable (scale - printer)
Power Adapters
Displays
Density determination KIT

Receipt Printer
RPANEL BOX
RS 232, RS 485 cables
Protective cover for balances
Under-Pan Weighing Rack
RS 232 cables (scale - printer)

Software

RAD-KEY

LabVIEW Driver

Device dimensions

PS 3500.R2.M Precision Balance

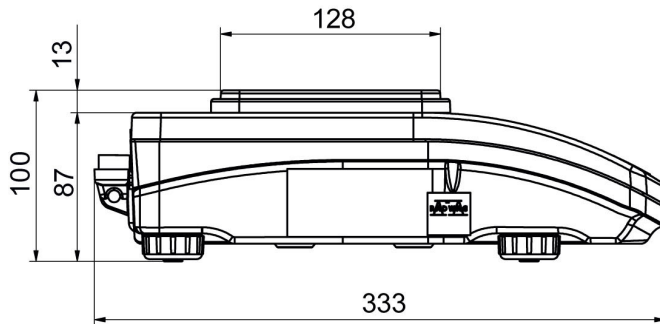

PS R, d = 1 mg

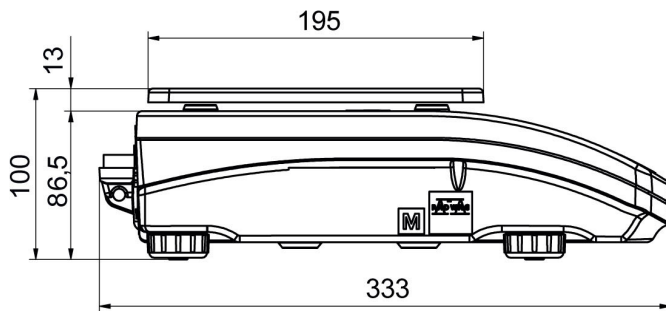
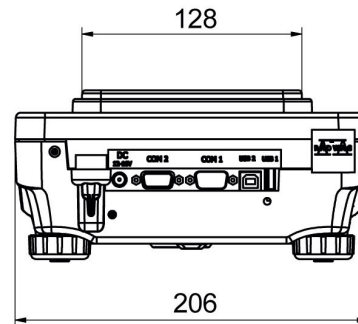

PS R, d = 10 mg

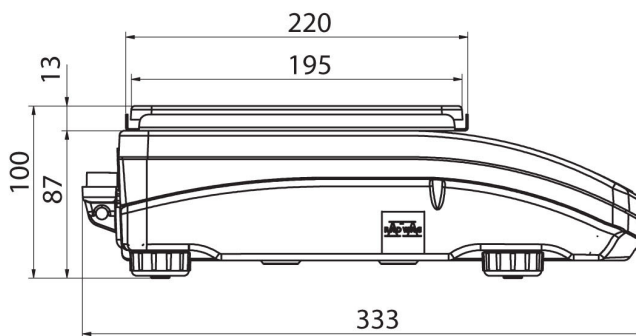
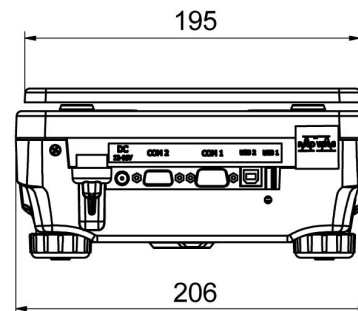

PS R.M, d = 10 mg

