



More information on the website  
[radwag.com/en/info,w1,C03](http://radwag.com/en/info,w1,C03)

### PS 750.R2.H Precision Balance



PS 750.R2.H Precision Balance

The drawings, photos and graphics used are for illustrative purposes only.

## Functions



Autotest



Dosing



Percent Weighing



Totalizing



Parts counting



Peak hold



Newton unit  
measurement



Statistics



Checkweighing



GLP Procedures



Animal weighing



Density determination

# Datasheet

	PS 750.R2.H Precision Balance
<b>Metrological parameters</b>	
Maximum capacity [Max]	750 g
Minimum load	20 mg
Readability [d]	0,001 g
Tare range	-750 g
Repeatability (Max)	0,0015 g
Repeatability (5% Max)	0,0005 g
Linearity	±0,003 g
Stabilization time	2 s
Adjustment	internal (automatic)
<b>Physical parameters</b>	
Leveling system	manual
Display	LCD (backlit)
Protection class	IP 54
Weighing pan dimensions	ø100 mm
Packaging dimensions	470×380×336 mm
Net weight	3,5 kg
Gross weight	5,5 kg
<b>Communication interface</b>	
Communication interface	2×RS232 <sup>1</sup> , USB-A, USB-B, Wi-Fi (option)
<b>Electrical parameters</b>	
Power supply	Adapter: 100 – 240V AC 50/60Hz 0,6A; 12V DC 1,2A Balance: 12 – 15V DC 0,4A max
<b>Environmental conditions</b>	
Operating temperature	+10 ÷ +40 °C

Repeatability is expressed as a standard deviation from 10 weighing cycles. Stabilization time depends on the ambient conditions and the dynamics of weighing pan loading; specified for FAST profile. 1 Barcode scanners, available as weighing instrument accessory, communicate with the instrument via RS232 interface exclusively.

\* Wi-Fi® is a registered trademark of Wi-Fi® Alliance.



## Accessories

Barcode scanners  
Cigarette lighter receptacle power supply cables  
USB cable (scale - printer)  
Power Adapters  
Antivibration Tables  
Displays

Receipt Printer  
RPANEL BOX  
RS 232, RS 485 cables  
Under-Pan Weighing Rack  
RS 232 cables (scale - printer)

## Software

RAD-KEY  
R Panel  
R-LAB  
E2R System

LabVIEW Driver  
Alibi Reader  
RADWAG Development Studio  
R.Barcode

# Device dimensions

## PS 750.R2.H Precision Balance

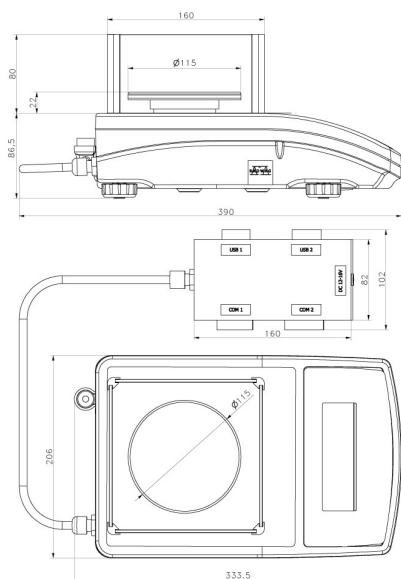

PS R2.H, d = 1 mg

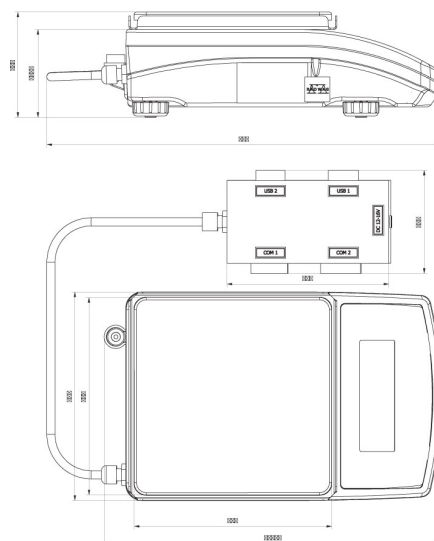

PS R2.M.H, d = 10 mg