



More information on the website  
[radwag.com/en/info,w1,GNN](http://radwag.com/en/info,w1,GNN)

**WAY 5.5Y.KO Mass Comparator**



WAY 5.5Y.KO Mass Comparator

The drawings, photos and graphics used are for illustrative purposes only.

**Datasheet**

	WAY 5.5Y.KO Mass Comparator
<b>Metrological parameters</b>	
E1 Calibration Range	2 kg ÷ 5 kg
E2 Calibration Range	500 g ÷ 5 kg
F1 Calibration Range	200 g ÷ 5 kg
F2 Calibration Range	20 g ÷ 5 kg
M1 Calibration Range	1 g ÷ 5 kg
M2 Calibration Range	1 g ÷ 5 kg
Maximum capacity [Max]	5,05 kg
Readability [d]	0,1 mg
Standard repeatability [5% Max]	0,15 mg
Standard repeatability [Max]	0,2 mg
Permissible repeatability	0,35 mg
Eccentricity (tested load)	0 mg*
Electric compensation range	-10 g ÷ +50 g
Stabilization time	20 s
Adjustment	internal
<b>Physical parameters</b>	
Display	10" graphic colour touchscreen
Weighing pan dimensions	ø90 mm
Weighing device dimensions	385×217×545 mm
Controlling device dimensions	249×170×72 mm
Anti-draft chamber dimensions	560×340×570 mm
Packaging dimensions	945×820×1260 mm
Chamber packaging size	820×850×630 mm
Net weight	39 kg
Gross weight	59 kg
<b>Communication interface</b>	
Communication interface	2×USB-A, USB-C, HDMI, Ethernet, Wi-Fi, Hotspot
<b>Environmental conditions</b>	
Operating temperature	+15 ÷ +30 °C
Operating temperature change rate	±0,5°C/12h (±0,3°C/4h)
Relative humidity	40% ÷ 60%
Relative humidity change rate	±5%/4h

Repeatability is expressed as a standard deviation determined for 6 ABBA cycles. Standard deviation is experimentally determined under ambient conditions for calibration of F2 class mass standards specified in OIML R111 (Table C.1.) document Eccentricity (tested load) – suspended self-centring weighing pan (available as an option): 0 mg \* Eccentricity (tested load): 1 d / mm

\* Wi-Fi® is a registered trademark of Wi-Fi® Alliance.



## Accessories

RFID Tags  
Antivibration Tables  
Additional modules  
Protective cover for balances  
Barcode scanners  
RS 232, RS 485 cables  
Label Printers

THBR 2.0 System - Ambient Conditions Monitoring  
Receipt Printer  
Suspended Self-Centring Weighing Pan for WAY 5Y.KO Manual Mass  
Comparator  
Fingerprint Reader  
RS 232, RS 485 cables  
RS 232 cables (scale - printer)

## Software

RAD-KEY  
RMCS System

RMCS Lite

## Device dimensions

WAY 5.5Y.KO Mass Comparator

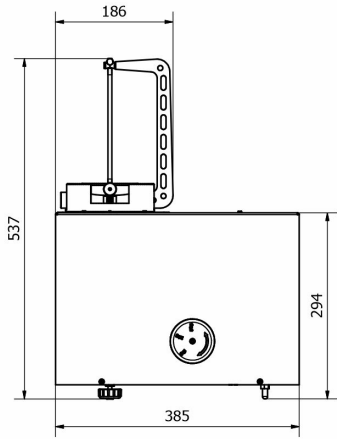

WAY 5.5Y.KO

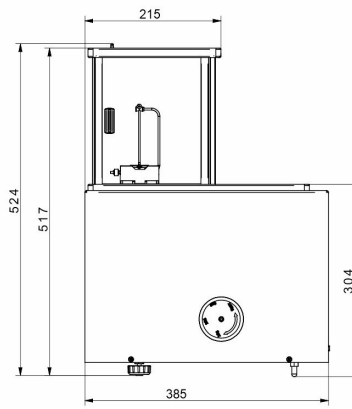
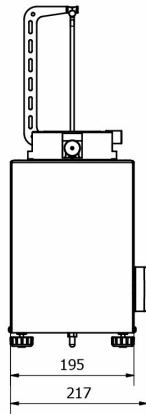

WAY 100.5Y.KO

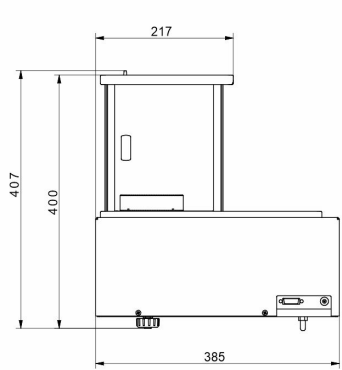
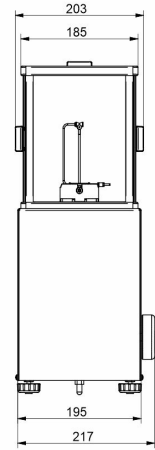

WAY 1200.5Y.KO

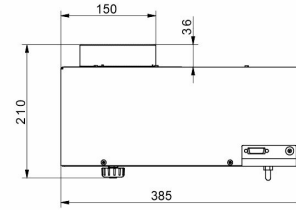
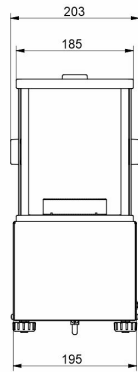

WAY 5100.5Y.KO

