



More information on the website
radwag.com/en/info,w1,ZYK

WLC 0.6/A1/C/2/IO Precision Balance



WLC 0.6/A1/C/2/IO Precision Balance

The drawings, photos and graphics used are for illustrative purposes only.

Functions



Plus/Minus Control



Percent Weighing



Totalizing



Parts counting



Internal battery



Peak hold



Newton unit
measurement

Datasheet

	WLC 0.6/A1/C/2/IO Precision Balance
Metrological parameters	
Maximum capacity [Max]	0,6 kg
Minimum load	0,5 g
Readability [d]	0,01 g
Verification unit [e]	0,1 g
Tare range	-0,6 kg
Repeatability	0,015 g
Linearity	±0,02 g
Stabilization time	3 s
Adjustment	internal (automatic)
OIML Class	II
Physical parameters	
Leveling system	manual
Display	LCD (backlit)
Weighing pan dimensions	128×128 mm
Packaging dimensions	430×270×190 mm
Net weight	3,6 kg
Gross weight	4,5 kg
Construction	
Protection class	IP 43
Communication interface	
Communication interface	2×RS232, USB-A, USB-B, 4 IN / 4 OUT
Electrical parameters	
Power supply	Adapter: 100 – 240V AC 50/60Hz 0,6A; 12V DC 1,2A Balance: 10 – 15VDC 0,6A max
Operation time on batteries	15 h (average time)
Environmental conditions	
Operating temperature	+15 ÷ +30 °C

Repeatability is expressed as a standard deviation from 10 weighing cycles. Stabilization time depends on the ambient conditions and the dynamics of weighing pan loading; specified for FAST profile.



Extra payment for verification



Accessories

Balance Storage Case
Antivibration Tables
Power Adapters
RS 232 cables (scale - printer)
Cigarette lighter receptacle power supply cables
Under-pan weighing
RS 232, RS 485 cables
Draft Shield

RS 232 – Ethernet Converter
Displays
Receipt Printer
AP2-1 Current Loop Unit
Protective cover for balances
RS 232, RS 485 cables
RS 232 cables (scale - printer)
RS 232 – RS 485 Converter

Software

RAD-KEY
R-LAB

Alibi Reader
Scales Editor 2.1

Device dimensions

WLC 0.6/A1/C/2/IO Precision Balance

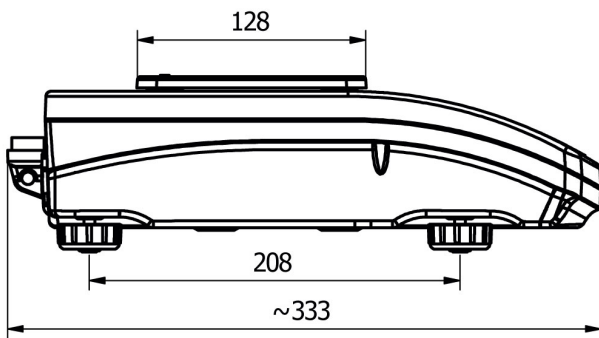

WLC A1

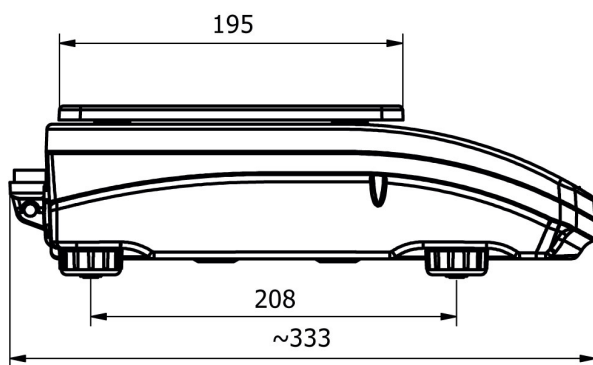
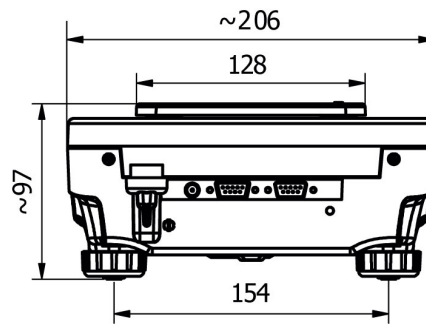

WLC A2

