

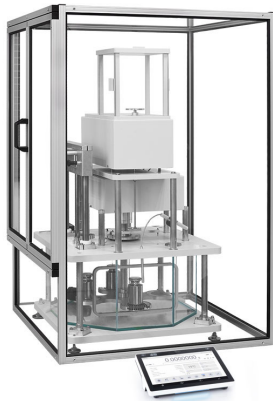

More information on the website
radwag.com/en/info,w1,T4L

AGV-2 20.5Y Automatic Comparator



AGV-2 20.5Y Automatic Comparator

The drawings, photos and graphics used are for illustrative purposes only.

Datasheet

	AGV-2 20.5Y Automatic Comparator
Metrological parameters	
E1 Calibration Range	1 kg ÷ 20 kg
E2 Calibration Range	1 kg ÷ 20 kg
F1 Calibration Range	1 kg ÷ 20 kg
F2 Calibration Range	1 kg ÷ 20 kg
Maximum capacity [Max]	26,1 kg
Readability [d]	1 mg
Standard repeatability [5% Max]	2 mg
Standard repeatability [Max]	3 mg
Permissible repeatability	6 mg
Electric compensation range	100 g ÷ +26,1 kg
Stabilization time	30 s
Adjustment	external
Physical parameters	
Display	10" graphic colour touchscreen
Magazine positions	automatic 2 positions
Weighing pan dimensions	ø220 mm self centering
Object diameters	25-145 mm
Electrical parameters	
Power supply	100 – 240 V AC 50/60 Hz
Environmental conditions	
Operating temperature	+15 ÷ +30 °C
Storage temperature	-20 ÷ +50 °C
Operating temperature change rate	±0,5°C/12h (±0,3°C/4h)
Relative humidity	40% ÷ 60%
Relative humidity change rate	±5%/12h (3%/4h)

Repeatability is expressed as a standard deviation determined for 6 ABBA cycles. Standard deviation is experimentally determined under ambient conditions for calibration of E1 class mass standards specified in OIML R111 (Table C.1.) document.



Accessories

RFID Tags
Additional modules
Protective cover for balances
Barcode scanners
RS 232, RS 485 cables

THBR 2.0 System - Ambient Conditions Monitoring
Receipt Printer
Fingerprint Reader
RS 232, RS 485 cables
RS 232 cables (scale - printer)

Software

RMCS Lite

RMCS System

Device dimensions

AGV-2 20.5Y Automatic Comparator

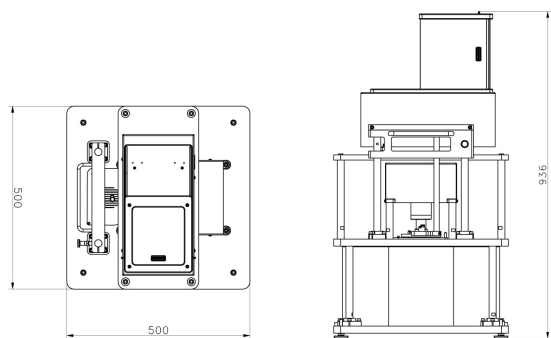

AGV-8/1000

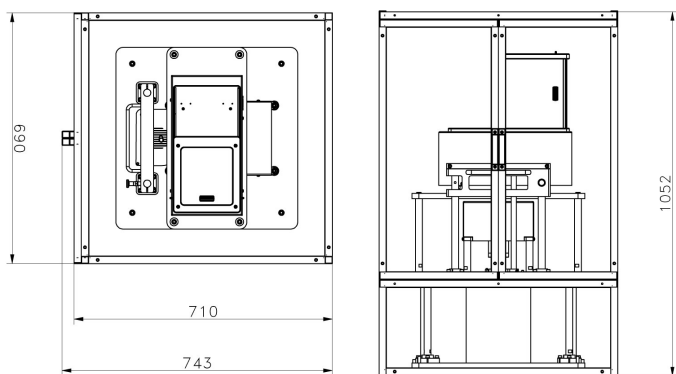

AGV-8/1000
Anti-draft chamber ver.1

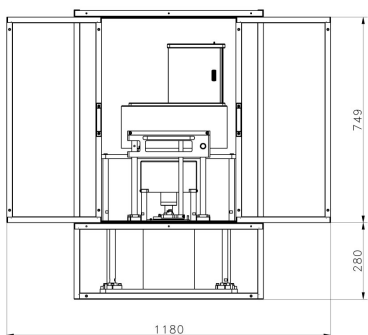

AGV-8/1000
Anti-draft chamber ver.2